

4

3

2

1

REVISIONS				
ZONE	REV.	DESCRIPTION	DATE	APPROVED
	1	PROTOTYPE RELEASE	6/11/14	OBM
	2	CHANGE LOCATION OF ITEM #5 #9, UPDATE COMPONENTS	1/20/15	OBM
	3	CHANGE 1725478 FROM 4 PIECE ASSY TO A FULL WELDED PART.	11/4/16	OBM

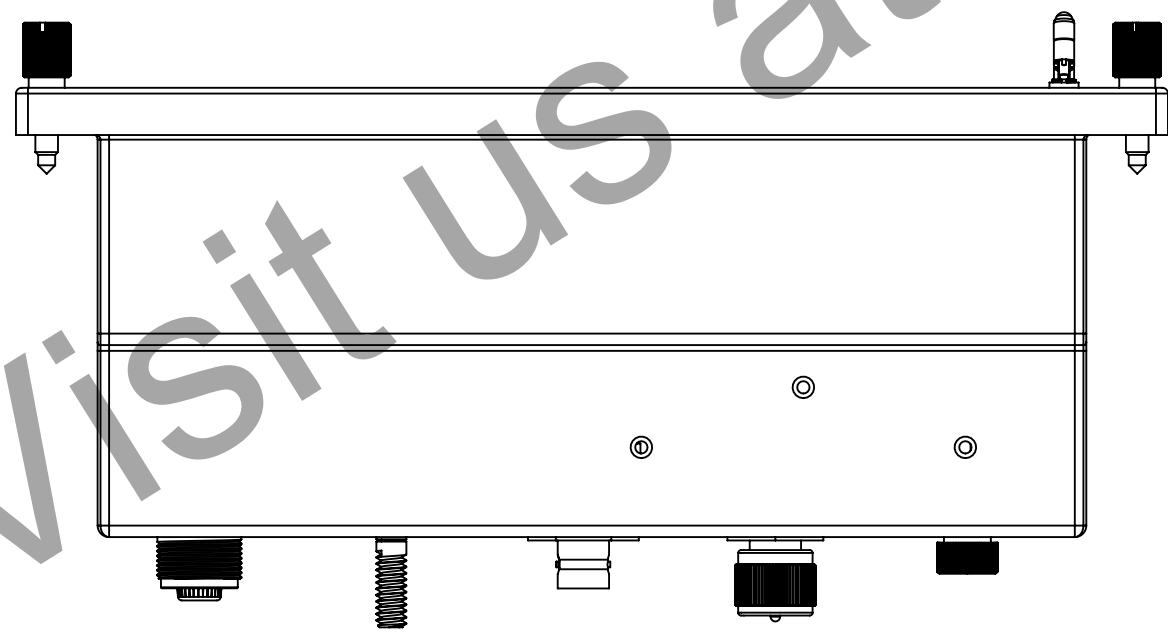
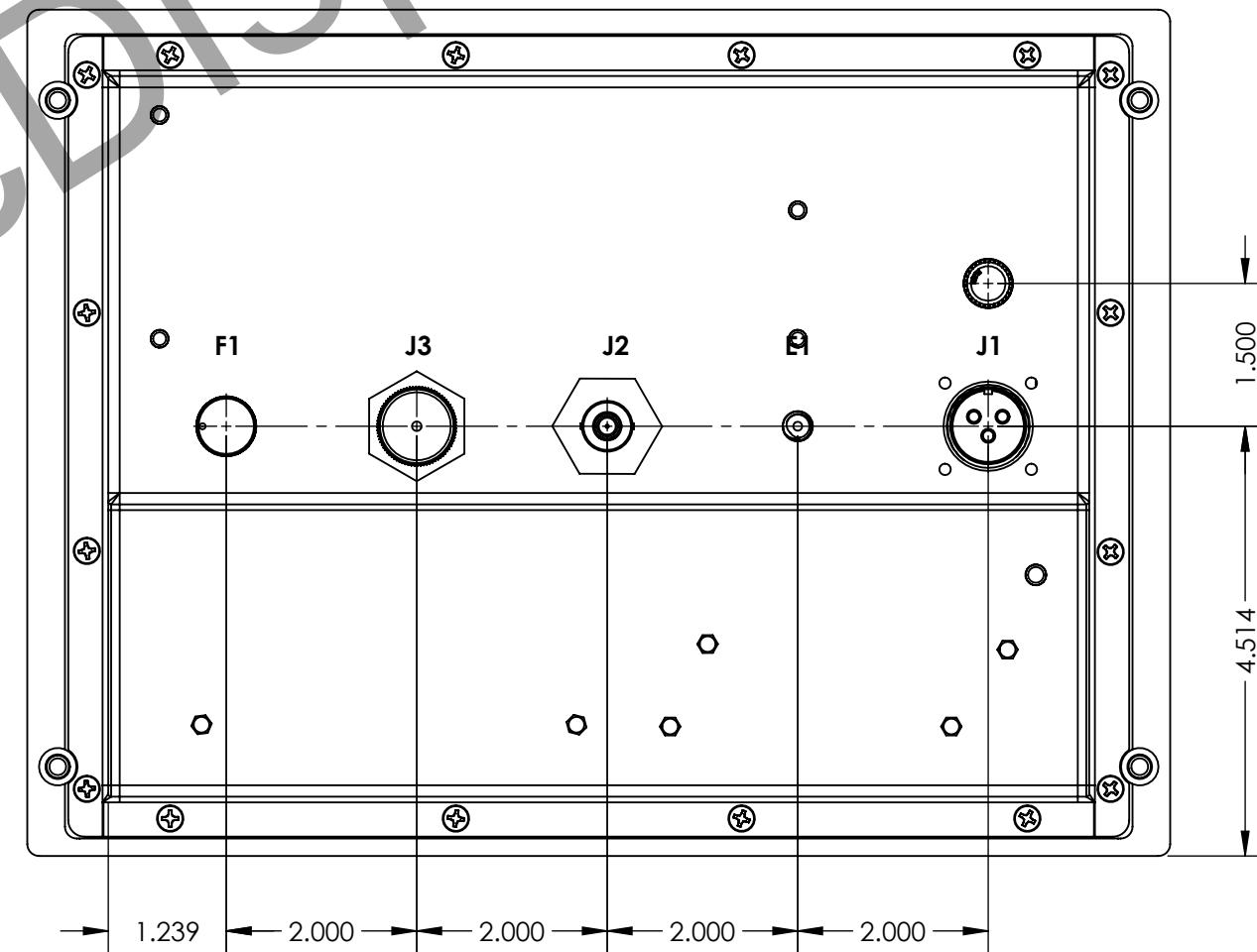
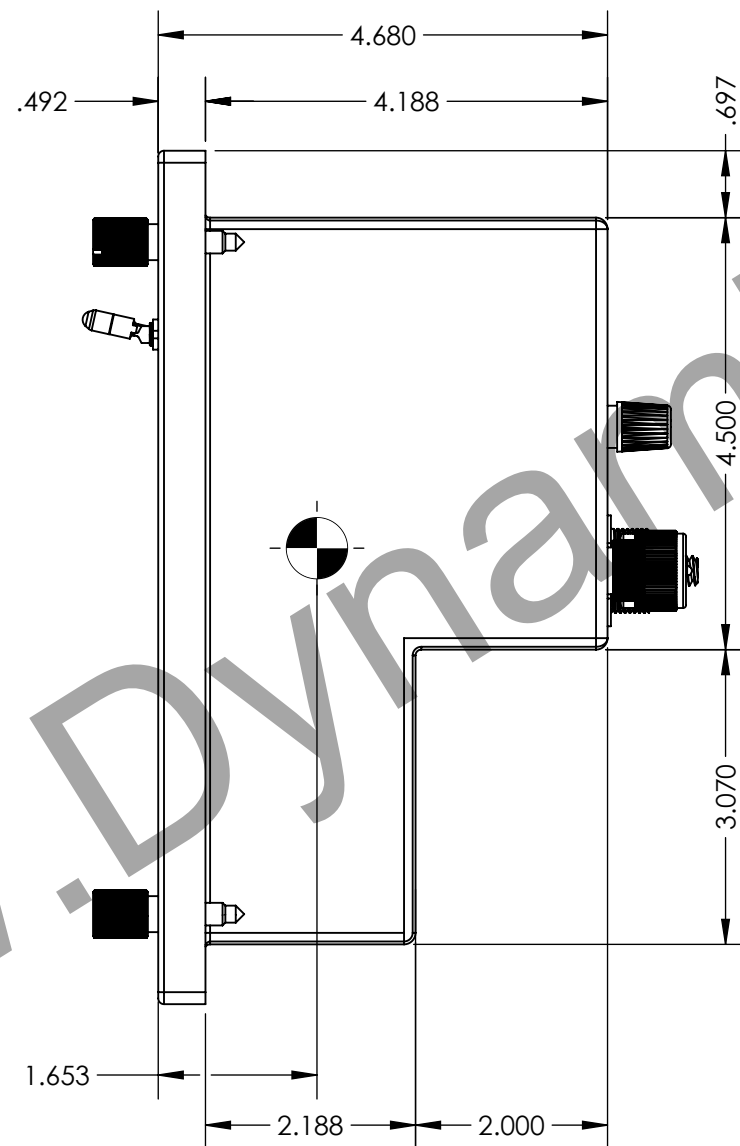
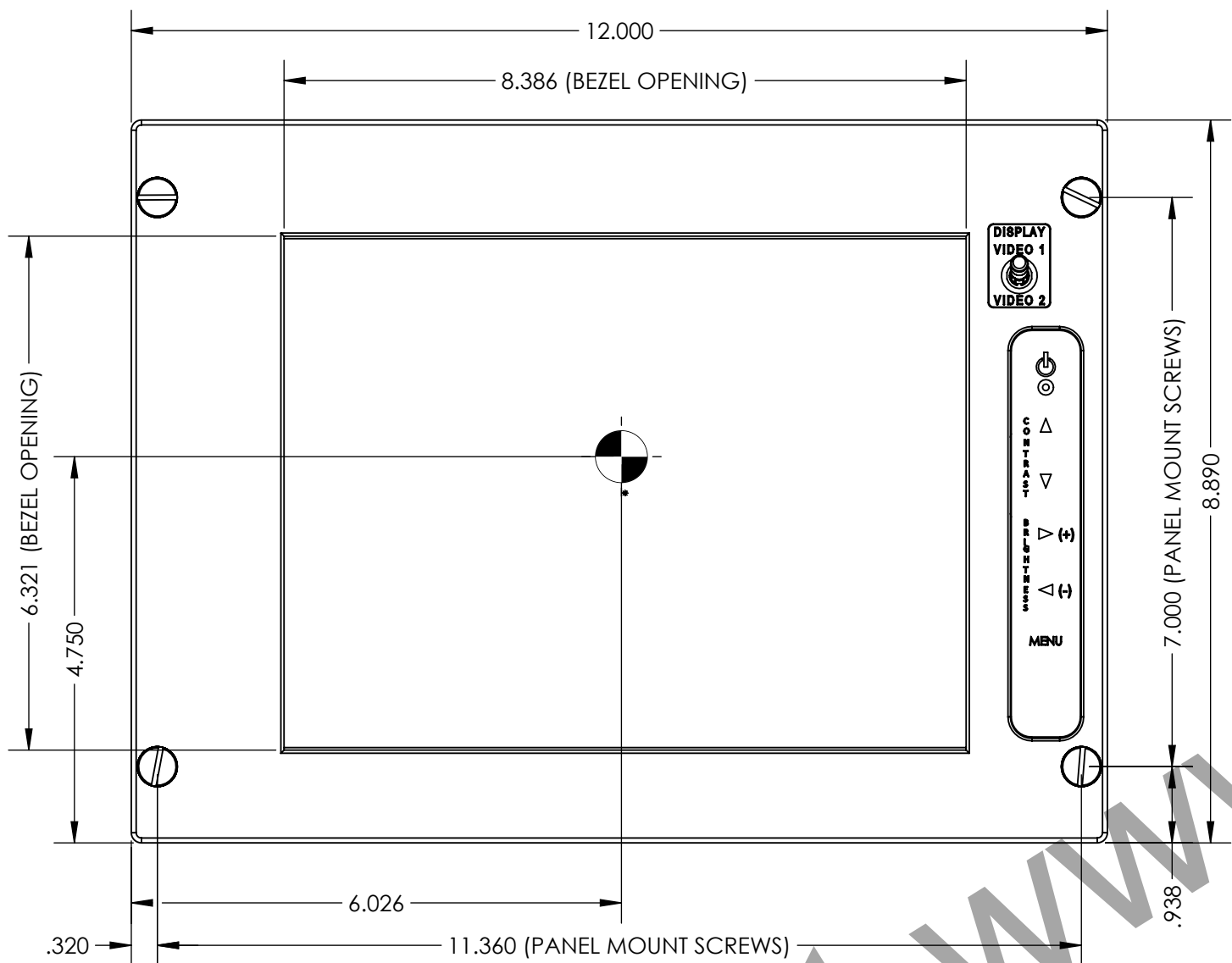
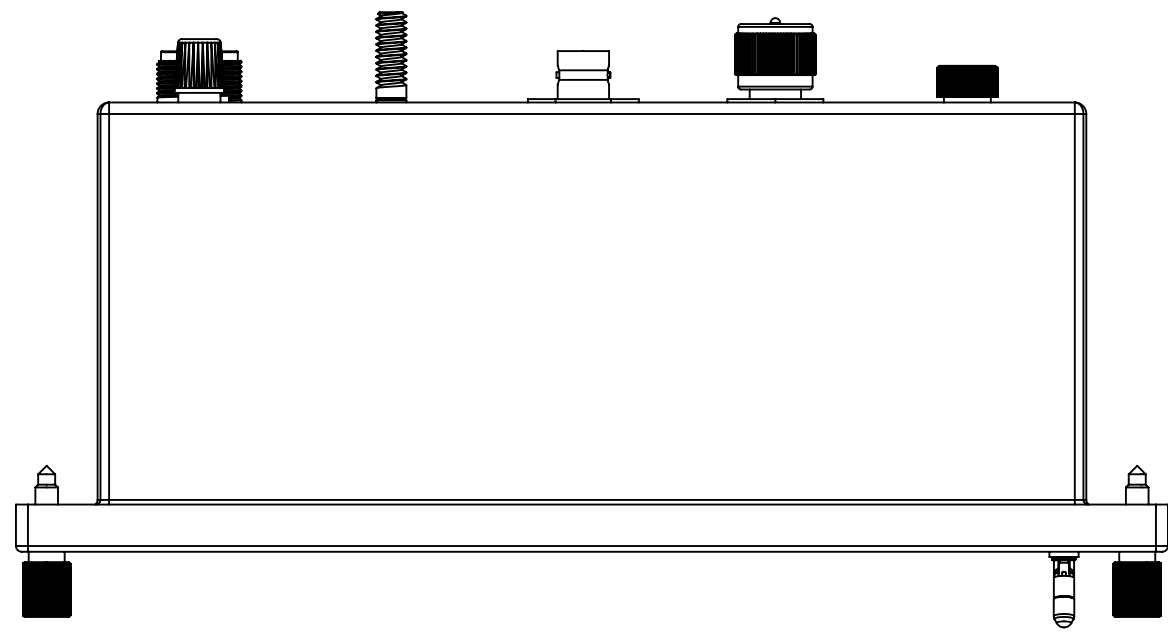

NOTES:
 1. TOTAL UNIT WEIGHT: 9.2 Lb Calculated.

PROPRIETARY AND CONFIDENTIAL
 THE INFORMATION CONTAINED IN THIS DRAWING IS THE SOLE PROPERTY OF DYNAMIC DISPLAYS, INC. ANY REPRODUCTION IN PART OR AS A WHOLE WITHOUT THE WRITTEN PERMISSION OF DYNAMIC DISPLAYS, INC. IS PROHIBITED.

UNLESS OTHERWISE SPECIFIED:		NAME	DATE
DIMENSIONS ARE IN INCHES	DRAWN	OBM	11/10/2015
TOLERANCES:	CHECKED	DR	11/10/2015
FRACTIONAL ±	ENG APPR.	OBM	11/10/2015
ANGULAR: MACH ± BEND ±	MFG APPR.	TJP	11/10/2015
TWO PLACE DECIMAL ±	Q.A.	MRC	11/10/2015
THREE PLACE DECIMAL ±	COMMENTS:		
INTERPRET GEOMETRIC TOLERANCING PER:			
MATERIAL:			
FINISH:			
DO NOT SCALE DRAWING			

Dynamic Displays, Inc.		
TITLE:		
OUTLINE DWG, CRO, MONO, ASSY, 10.4"		
SIZE	DWG. NO.	REV
C	0014139	3
SCALE: 1:2	SHEET 1 OF 2	

4

3

2

1